



User / installation manual Viewline Slide and turn system

Version: ENG - February 2023



www.glassgardenroom.co.uk



Contents

1. Introduction and Assembly Videos	3 4
2. Safety Precautions and Warnings	5 6
3. Product Description	6 7
4. Parts Overview	7 9
4.1 Exploded view	9
4.2 Checking delivery	10
4.3 Parts	11
5. Assembly preparation and placing the order	14
5.1 Mounting conditions	15
5.2 Checking tools and accessories	15
5.3 Measuring & determining measurements	16
5.4 Determining the orientation	16
5.5 Determining the number of doors	17
5.6 Placing an order	18
6. Mounting	22
6.1 Pre-mounting the frame	25
6.2 Installing the frame in the opening	25
6.3 Mounting the main door	28
6.4 Assembling the slide and turn doors	34
7. Adjust and readjust the slide and turn system.	37
7.1 Adjusting all doors in closed position	37
7.2 Adjusting the locking/unlocking mechanism of all slide and turn doors	37
8. Troubleshooting	
9. Maintenance	
10. Disposal	
11. Warranty	
12. Contact	

THIS MANUAL SHOULD BE RETAINED FOR FUTURE REFERENCE!

We recommend that you contact your supplier for the duration and conditions of the warranty. We also refer to our General Terms and Conditions of Sale and Delivery which are available on request. Viewline BV declines all responsibility for damage or injury as a result of not following this manual carefully and not taking the usual care during transport, assembly, use and maintenance of the slide and turn system. As a result of continuous improvement efforts, the product may differ in detail from what is described in this manual. For this reason, the instructions given are only a guideline for installing the product mentioned in this manual. This manual has been compiled with the utmost care, but Viewline BV cannot be held responsible for any errors in this manual or for the



consequences thereof. Furthermore, all rights are reserved and no part of this manual may be reproduced in any way.

1. Introduction and Assembly Videos

Congratulations on the purchase of your Viewline Slide and turn System!

Before you can start enjoying your Slide and turn system, it must be properly mounted. In this manual you will find all the steps that you need to go through for the correct installation of your Viewline Slide and turn system. We advise you to read through the entire manual at your leisure before starting the installation.

Before starting installation, check whether all necessary parts are included. Please observe the applicable regulations for your safety. This also guarantees the safety of the installed Slide and turn system. If you have any questions, please do not hesitate to contact your relevant Viewline dealer.

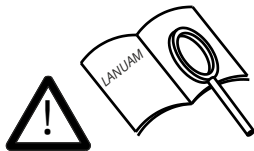

To get a better idea of the text in this manual, we refer to 3 animation videos to clarify things. These videos are for support purposes only and may differ slightly from this manual. ***In deviating cases, the manual is always leading!***



How the system works
<https://youtu.be/E3MM8PmI8-4>



Mounting the system
<https://youtu.be/4dY-utjdiDs>



Adjusting the system
<https://youtu.be/FTINdbI-j2c>

This manual should be kept in a safe, dry and shady place. In case of damage or loss, the user must request a new copy of the manual from the supplier.



2. Safety Precautions and Warnings



Important: Read the safety precautions and warnings before assembling the Slide and turn System.

- Carefully follow the instructions and guidelines as described in this manual during installation. Never change the order of the actions to be performed. If something is not clear about the mounting, please contact your Viewline dealer.
- Subject to technical changes without written notice.
- We recommend that the assembly of the slide and turn system is carried out by 2 persons (qualified technicians / recognized installers) as standard.
- Check the delivery immediately after receipt. In the event of damage or incomplete delivery, please contact your dealer immediately.
- The materials should be stored in a dry, ventilated area, not exposed to direct sunlight.
- Carefully open the package. Be careful not to damage the product.
- To prevent damage to your Slide and turn system, place the parts on a soft, clean and flat surface. PLEASE NOTE that there are no scratches.
- Be extra careful with the edges and corners of the door panels.
- Never stand on the door panels.
- Adding or omission of parts, or the processing or processing of materials other than in the prescribed manner can adversely affect the safety of the slide and turn system and is therefore strongly discouraged!
- Secure the mounting location with a safety tape so that third parties are kept at a distance.
- Always wear the correct protective clothing (work gloves, dust mask, safety glasses, shoes with anti-slip, etc.) when performing the work.
- Always place a ladder on a firm stable surface.
- Mount the slide and turn system on a flat, stable foundation or surface. Make sure all fasteners are properly tightened. Please check this regularly.
The type of fastener for the top rail, bottom rail and U-profiles for the side connection depends on the type of substrate (steel, concrete or wood).
- The fasteners must be determined by the installer and are not supplied as standard.
- Contaminants can get into the bottom rail. In the interest of the service life it is important to keep the rail clean.
Use enough water, soft material and a sponge for cleaning and washing. Only use neutral cleaning agents. No acid or alkalis. Solvents (Dishwashing Liquid and Glassex) are allowed to remove greasy soiling.
- Make sure that fingers and limbs do not get caught between the door panels and/or frame profiles.
- Dispose of the product in accordance with local laws and regulations.
- Viewline BV does not accept any liability for damage or injury caused by not (strictly) following the safety regulations and instructions in this manual, or due to negligence during assembly, use and maintenance of the product and any associated accessories. Viewline BV is not responsible for any form of damage.

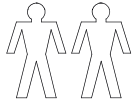



3. Product Description and Operation

Viewline slide and turn systems are very suitable as a closure for your patio roof, veranda, garden house, log cabin, etc. The Slide and turn system consists of a frame, a main door and one or more slide and turn doors.

The main door is (based on order) placed on the left or right side and hinges on the side of the frame. The system can be opened by means of a key (multi-point lock) and a latch. The user can then slide the slide and turn doors one by one in the direction of the main door so that it locks here, so that it can then (after unlocking the espagnolette) be turned open 90 degrees.

The entire frame profile and the individual doors are provided with double brush profiles, the profiles enclose each other in a closed position, this ensures stable guidance and good wind and waterproofing. In addition, the slide and turn system protects your belongings against burglary.

The system is supported by the construction under the wall (instead of suspended systems). At the bottom of each slide and turn door are wheel systems with plastic running wheels that roll over the bottom rail. The carriage is adjustable in height and there is an adjustment option between the doors. This allows vertical seams between the door panels and the frame to be adjusted *. The bottom rail has water drainage slots for draining leakage water from the rail.

The door panels are made of 6 mm laminated safety glass with an aluminum frame around it. The door panels are available with an installation height of 1650 to 2500 mm and a width of 670 to 1100 mm. Depending on the installation size, the system can contain up to 7 doors.

** The doors can be adjusted to a certain extent. In the base, the wall must be mounted flat, at right angles and level.*

Details

Colours	Anthracite structure (RAL7024), Black structure (RAL9005)
Type of glass	Laminated safety glass (33.1)
Glass thickness	6 mm
Number of doors	2 - 7 doors
Layout	Main door Left / Main door right
Door	from 700 to 1200 mm (variable depending on installation dimensions)
Frame height**	from 1650 to 2500 mm (variable based on order)
Frame width**	from 1600 to 7000 mm (variable based on order)

The type of fastener for mounting the frame depends on the type of connecting frame (aluminium, steel, concrete or wood). The fasteners must be determined by the installer and are not supplied as standard.

**** NOTE: Order the frame on the actual frame size. See chapter 5.3.3. for exact measuring instructions!**



4. Parts overview

4.1 Exploded-view

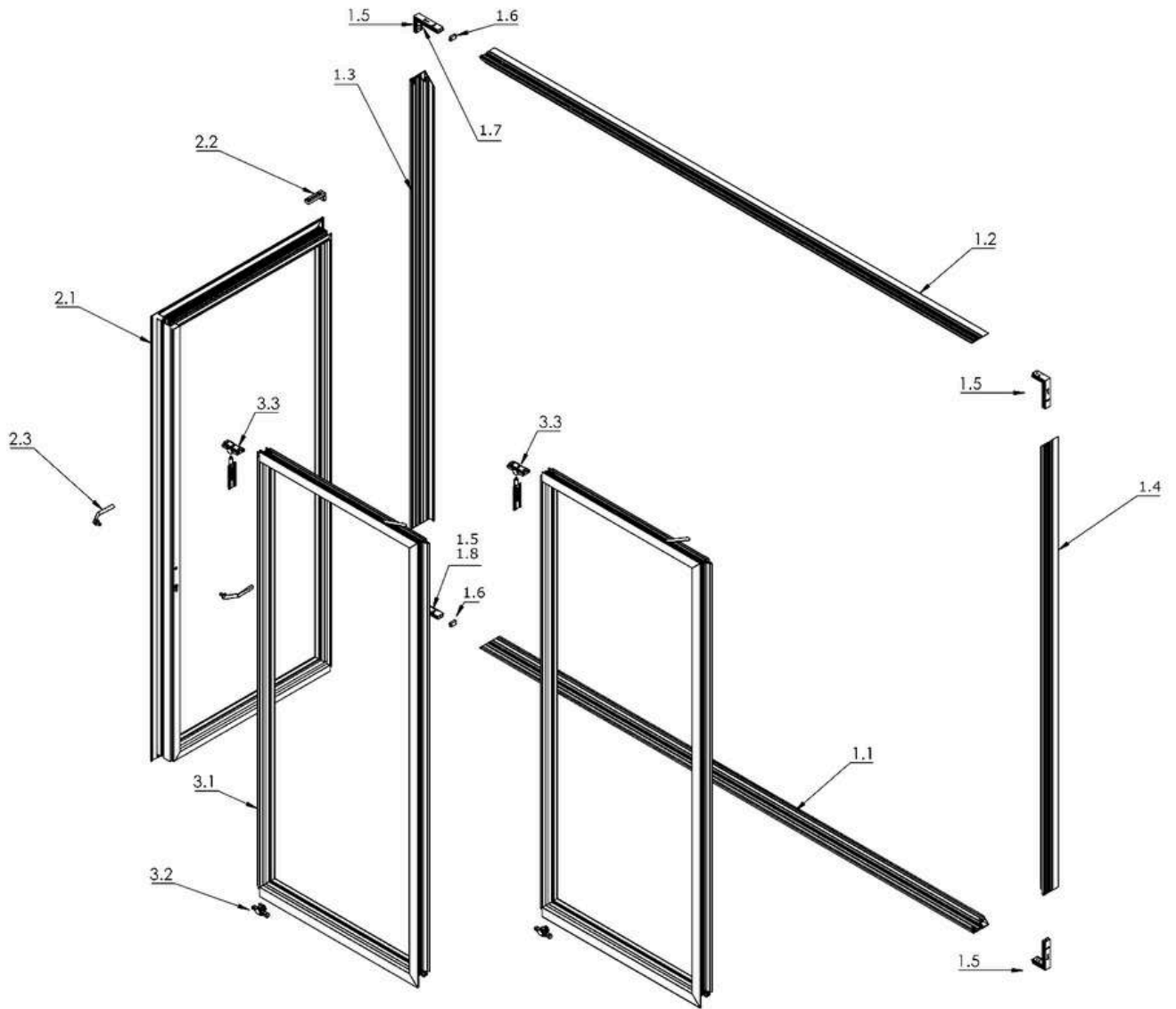



4.2 Delivery check

In this manual a Viewline Slide and turn system is shown with example dimensions (W x H) 2.9 x 2.1 m, consisting of 1 left-hand main door and 2 slide and turn doors. This example is illustrative only. The type and number of parts supplied depends on your order. Note: Always check the delivery note of the delivered parts for quantity and quality. Any visible defects must be reported in writing within 7 days of delivery.

4.3 Parts list

Check the delivered parts carefully for quantity and quality with the order form.

Frame parts (1):

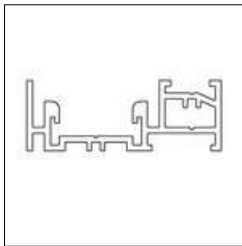

1.1 Under frame profile
(bottom rail assembled with
corners and hinge) (1x)

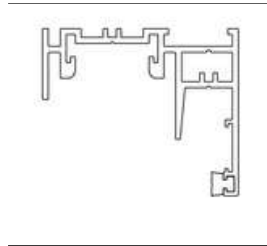

1.2 Above frame profile
(top rail assembled with
corners and hinge) (1x)

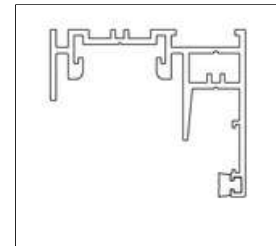

1.3 Left frame profile (1x)
1.4 Right frame profile (1x)

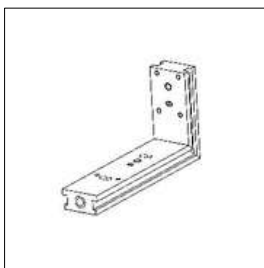

1.5 Connecting corner
frame profiles (4x)
(Pre-assembled)

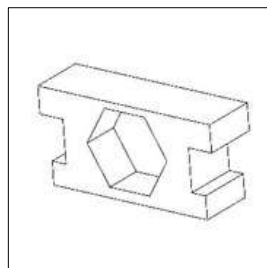

1.6 Starter block
carriages (2x)
(pre-assembled)

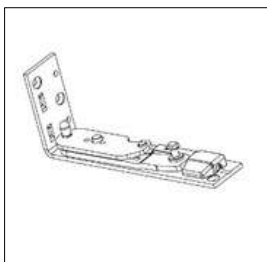

1.7 Hinge bottom
main door (1x)
(Pre-assembled)

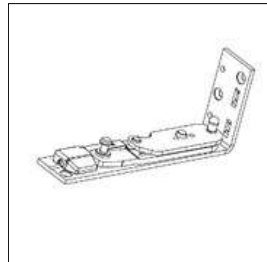

1.8 Hinge top main
door (1x)
(Pre-assembled)



Main door parts* (2):



2.1 Main door (1x)

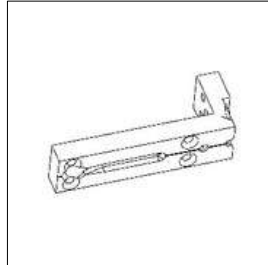

2.2 Corner band hinge (2x)
(pre-assembled)

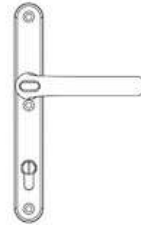

2.3 Door handle set
(1x)

Parts Slide and turn door* (3):



3.1 Slide and turn door
(1x)*

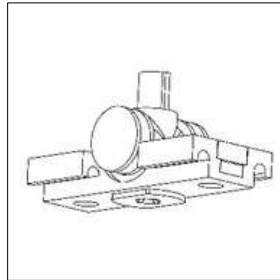

3.2 Under carriage (1x)*

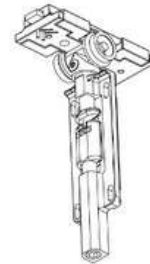

3.3 Overhead carriage (1x)*
(pre-assembled)

** The number of doors with associated parts depends on the composition of your ordered slide and turn system and can be a multiple of the above numbers.*



5. Assembly preparation & Place order

5.1 Assembly conditions

Surface & opening for mounting

- There must be a good flat stable surface for the construction of the slide and turn system.
- The surface must be flat and level.
- The bottom rail must be sufficiently founded. The substrate must not sag.
- The place where the frame is mounted must be firm, level and flat.
- The frame must be mounted at right angles and level. If necessary, fill with filler blocks (at least every 50cm).

The frame must be anchored on all sides.

The location where the sliding/turning system is to be installed must be ready for construction and free of obstacles (garden furniture, flower boxes, etc.) so that technicians can carry out their work without hindrance.

- The substrate must be free of obstacles such as NUTS pipes (such as power cables, etc.).

Dimensions

- A Viewline Slide and turn system is available with an installation height of 1650 to 2500 mm.
- A Viewline Slide and turn system has a maximum width of 7 meters. This maximum width is based on a composition of 7 doors consisting of 1 main door (side) and 6 slide and turn doors.

Screwing and drilling

- Do **NOT** drill, grind or machine the door panels.
- Drill round screw holes (4mm) in all frame profiles at a distance of +/-20cm from the side. Approx. 50cm to the next 2 holes for mounting. Preferably do not screw into the rail where the carriages roll along.
- Countersink the holes with $\varnothing 10\text{mm}$. Make sure the head of the screw does not protrude.
- Mount the profiles with stainless steel screws with countersunk head.

Note: If you continue to tighten the screws while they are already tight, the screw head may break.

Careful screwing, in the appropriate position for your screw driver, is recommended.

Removing protective film

- It is recommended that you only remove the protective film from the aluminum parts as the last step to prevent possible damage.

Warranty is void if the Viewline Slide and turn system is not assembled and mounted in accordance with the guidelines.

The slide and turn system is a custom product and cannot be returned if incorrect measurements have been taken!



5.2 Checking tools and accessories

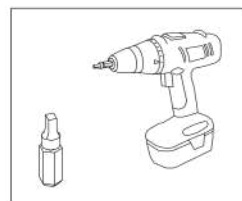
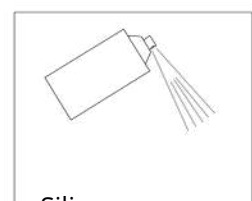
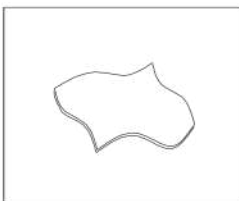
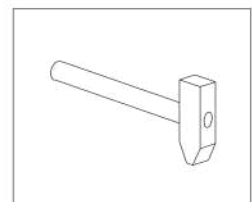
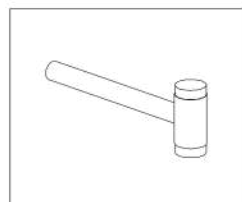
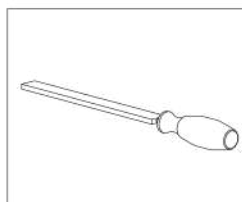
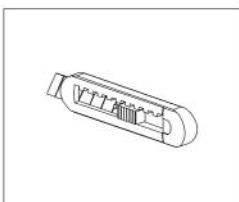
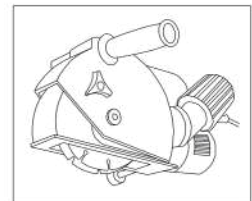
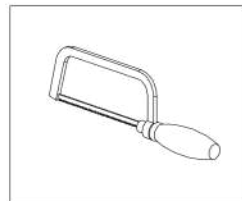
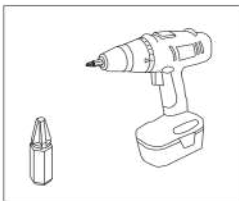
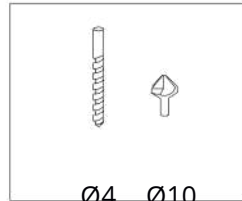
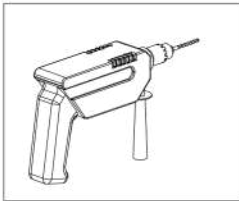
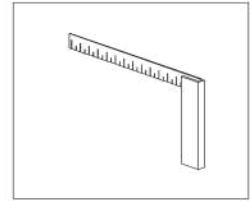
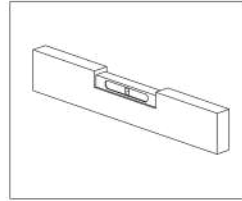
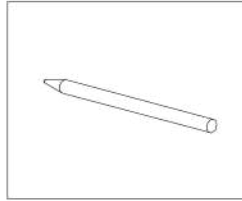
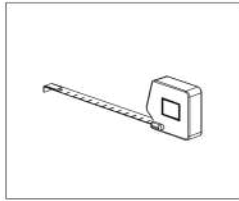



5.3 Measure & determine measurements

5.3.1 Checking the installation opening for flatness and level

You should preferably ***measure in combination with a laser/laser spirit level*** to ensure that all sides of the opening where the product is installed are level and flat.

The slide and turn system is a custom product and cannot be returned if incorrect measurements have been taken!

Before mounting, check that the opening is completely level on all 4 sides, check that the corners of the opening are completely square and that the sides are flat.

- Check that the surface is flat and level.
 - There should be no height differences in the ground. If this is the case, you should smooth it out first!
Check whether the subsoil is stable and sufficiently founded (by means of a tube or concrete strip).
 - To guarantee proper functioning of the system and to prevent adjustment problems, the substrate must ***be permanently stable***. The sinking of the foundation can make it impossible to adjust the system in the future.
- Check that the vertical sides are flat and level.
 - These sides must be stable. Make sure your roof is properly secured.
- Check that the top connection is flat and level.
 - There may be no slope of, for example, a gutter, nor should the gutter sag.



5.3.2 Measure opening

When you are going to measure the clear dimensions of the opening, it is important to measure them both in width and height at at least three different points of the opening, so that you can determine the correct dimensions. **When you measure, make sure the sides are level!**

- Width of the installation opening (B):
measure at the top, in the middle and at the bottom of the opening
- Height of the installation opening (H):
measure to the left, in the middle and right of the opening.
- Thickness of wall, facade or upright.
The installation depth of the frame is 66mm (including doors 75mm)

The smallest size that is measured is leading when determining the frame size.

ATTENTION: If it appears that the opening is not level and/or flat, it must be filled with adjusting blocks. In this case, you should order your frame smaller than the 6mm correction that applies to a square/straight opening. Make sure you know which situation applies to you. (see next page)

ATTENTION: There are situations where the smallest size is not sufficient. If the 2 horizontal or vertical surfaces run parallel to each other, but are not level, this must be taken into account. Otherwise the frame can never be placed level, resulting in adjustment problems. Use the images on the next page as a reference for your situation.

ATTENTION: Check for protruding parts that prevent the frame from being installed flat. This depends on the surface where the frame will be placed. These irregularities must first be filled/removed. Measure from these protruding parts to determine the smallest size.

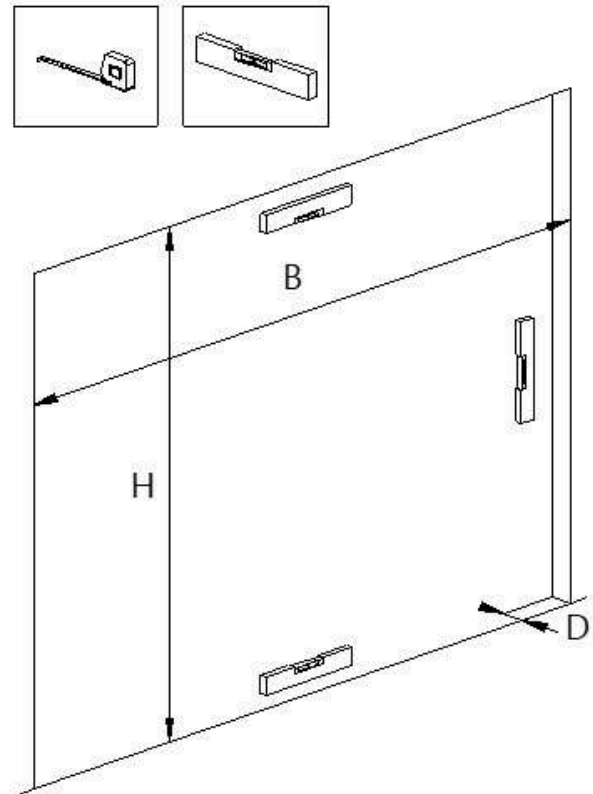

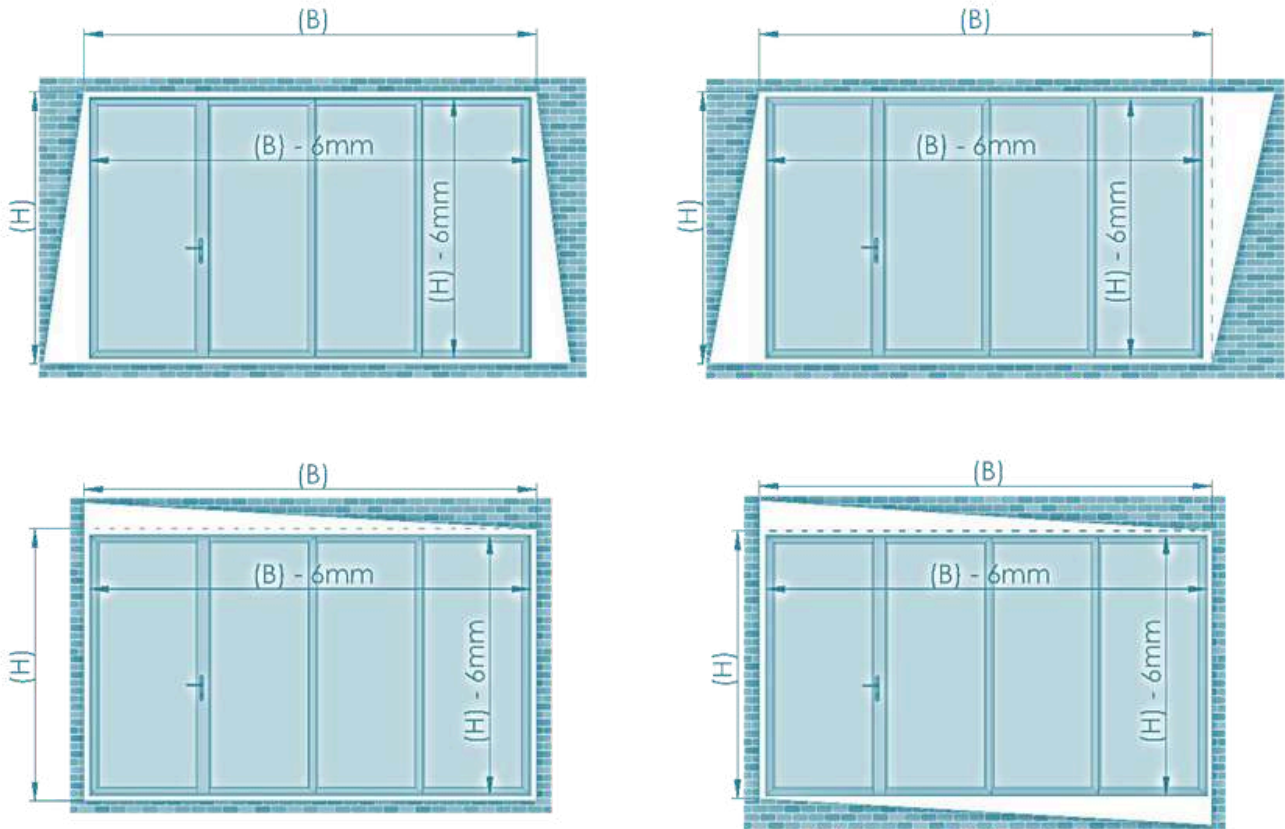

The above situations can occur, make sure you order the frame in the correct width. Correct the size for opening sides that slope away.



5.3.3 Determining frame dimensions

You determine the frame size by taking the smallest width and height size (or corrected size, see above situations in which the measured size does not correspond to H or B).

You then subtract 6 mm (3 mm on both sides) from this measurement so that you have enough clearance to place the frame.

Frame width = $W - 6\text{mm}$

Frame height = $H - 6\text{mm}$

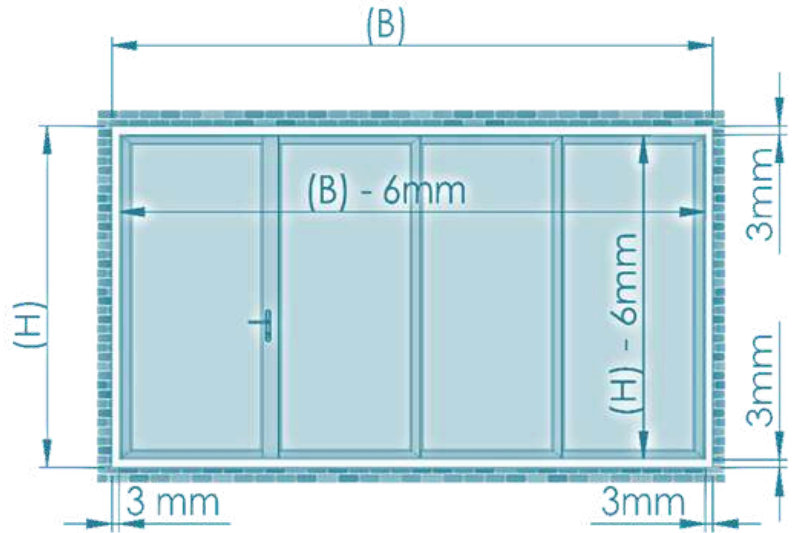

***You are responsible for the clearance you use. We recommend 6 millimetres when you have taken into account the flatness and levelness of the connecting building elements. You are responsible for the ordered frame size.**

5.4 Determining orientation

The slide and turn system can be ordered with the doors oriented to the left or right (pass door hinged on the outside of the frame). Please note that when you place an order, the main door is oriented left or right from the position where the door opens towards you. The adjacent doors can be pushed towards the main door to open here. See the situations below.

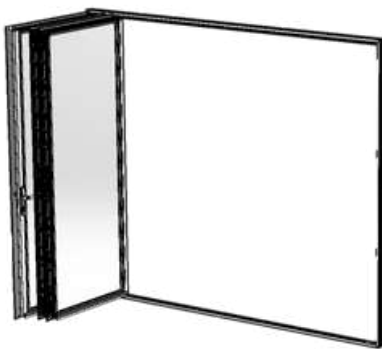

Left Oriented

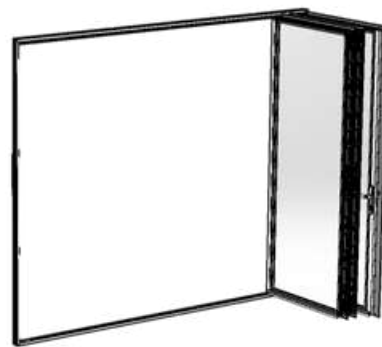

Right Oriented



5.5 Determining the number of doors

Depending on your desired installation width, you can choose how many doors you want the system to contain. The figure below shows the number of doors that a system can contain based on a certain frame width. A system contains at least 2 doors.

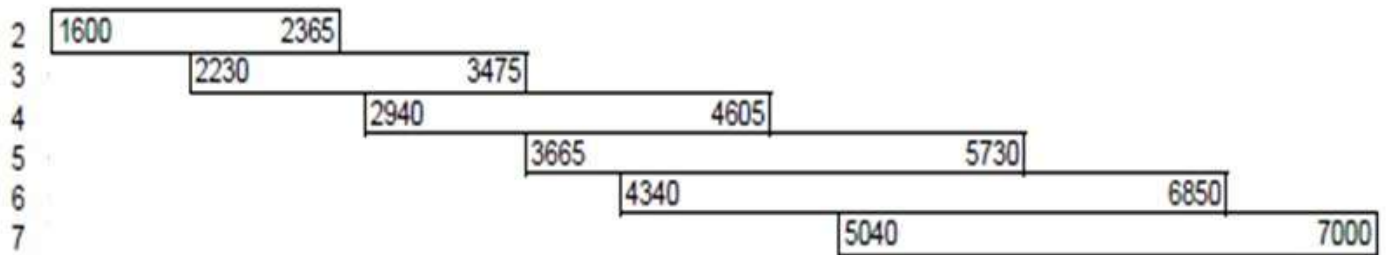

Example: You want to order a 4500 mm frame. Based on this width, the system must contain at least 5 doors. Additional doors can be ordered at an additional cost. For 4500mm you can optionally choose a 6 or 7 door system.

5.6 Place order

When you have measured, calculated and checked the dimensions of your frame, you can place the order for your slide and turn system. You do this by filling in the order form.

(Please note that the dimensions you provide us with are the actual frame dimensions. You must calculate the clearance for installation yourself.)

The system size to be ordered is:

Frame size width, Frame size height, Number of doors on the left, Number of doors on the right

Note: The slide and turn system is a custom product and cannot be returned if measured/ordered incorrectly!



6. Assembly

6.1 Pre-assembling the frame

1. Determine the bottom (1.1), top (1.2) and sides (1.3 & 1.4) of the (customized) frame profiles.
2. Lay out these frame profiles on 4 trestles in the shape of the frame, with the high sides of the profiles at the bottom and some space between the corners.

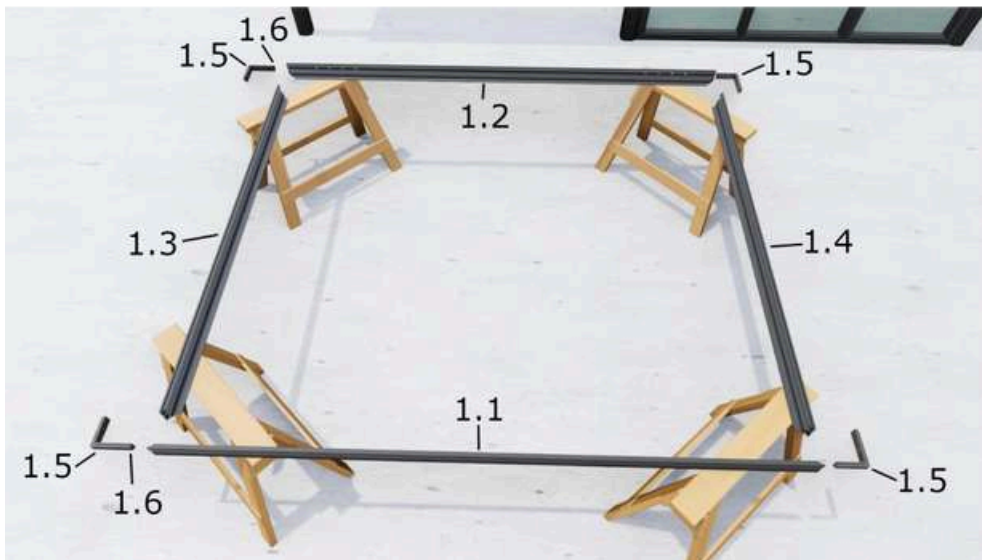

3. Determine the position of the main door in the frame (see order)
4. Form a frame by sliding the remaining ends of the mounting corners with top and bottom profile together in profiles 1.3 and 1.4. Tighten it using the remaining Allen screws in the corners.





6.2 Installing the frame in the opening

1. Lift the assembled frame from the trestles with 2 people and place it in the opening.

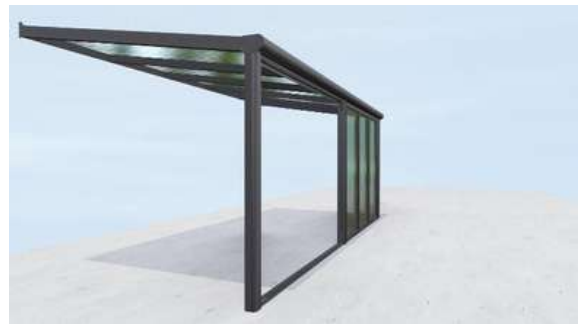

2. Determine the position of the mounting holes to be drilled, make sure they are in a position where there is enough material to screw in.

3. Mark the drill holes in the screw rail of the frame profiles. Mark this at +10 cm from the connection corner at a distance of approx. 50 cm to the next 2 holes. Drill the holes \varnothing 4mm. Countersink the holes \varnothing 10mm. The screw must be fully countersunk.

NOTE: Use the screw rail (see picture next to it) This is partly due to the position relative to the gutter, screws can exceptionally be placed in the raceway; Take extra care here that the screw head is completely recessed because of the blocking of the carriages.



4. Check that the bottom rail is level, the corners of the frame are square and the sides of the frame are level. Make sure that each screw spot is sufficiently filled by means of shims. The profiles must not shift/move/deform during screwing. Check with a laser or string whether the profile is flat.



NOTE: Installing the top and bottom rails flush and parallel is the most essential starting point for installing the Viewline system!



5. Screw the profiles to the wall or Pillar. The type of fastener depends on the type of substrate (steel, concrete or wood).
6. Check again whether the frame is mounted perpendicularly and is level. The bottom and top rails must lie completely flat. ***An incorrectly mounted frame will cause adjustment problems in the rest of this manual!***

6.3 Fitting the main door

1. The hinges (1.7 and 1.8) are already pre-assembled on the top and bottom rails.
2. To install the main door, the top hinge (1.8) must be removed. It can be removed from the top rail by means of the 5 screws.
3. Make sure that the bottom hinge (1.7) in the frame is in closed position.
4. Lift the main door and place it in "closed position" with the bottom corner strap (2.2) on top of the closed bottom hinge (1.7).

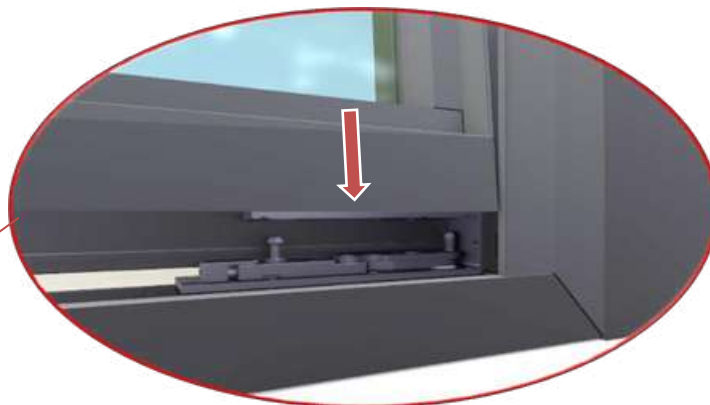



5. The main door can then be opened, while it is supported by a second person! be rotated 90 degrees. Make sure that this door is permanently supported by the second person. Failure to do so may damage the hinge.
6. Check whether the bottom hinge opens when the main door is opened.
*If this is not the case, the corner band has not been placed correctly on the hinge.
Then repeat steps 2, 3 and 4.*
7. Then place the top hinge (1.8) on the top corner band (2.2) of the main door.

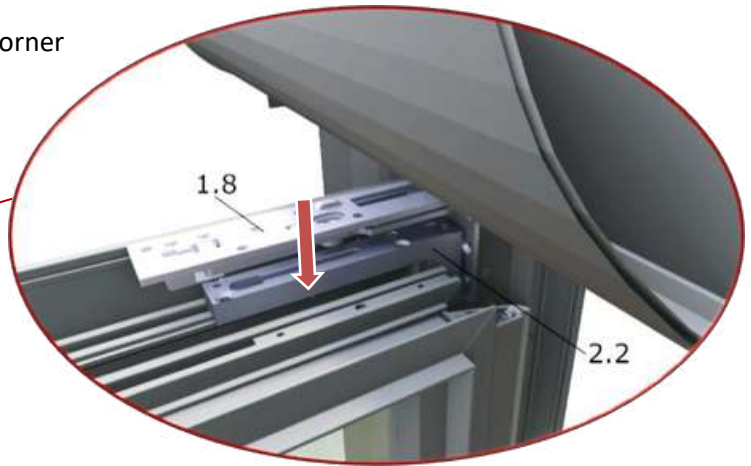

8. Then turn the hinge open by hand while it is in the top corner band. This will bring it into a straight position with the top connection angle (1.5) of the frame.
 - The hinge must be in the same line as the bottom hinge; adjacent to the low outer side of the frame profile.
 - The mounting holes of the top hinge (1.8) now coincide with the mounting holes of the top joint corner (1.5).
 - The main door is currently still open and needs to be supported by the second person.





9. Screw the hinge to the plastic connection corner (1.5) by means of the removed screws
- ***Tighten the screws by hand, taking care that the screws do not damage the screw thread in the plastic.***
 - 1 screw can be difficult to reach, you can reach this more easily by turning the main door a little.



10. ***ATTENTION!*** Before closing the door, make sure that the adjusting screw in the bottom corner band of the main door is screwed in 2mm. ***Make sure that the corner strap is 2mm up from the hinge. Skipping this step will damage the bottom hinge!!***

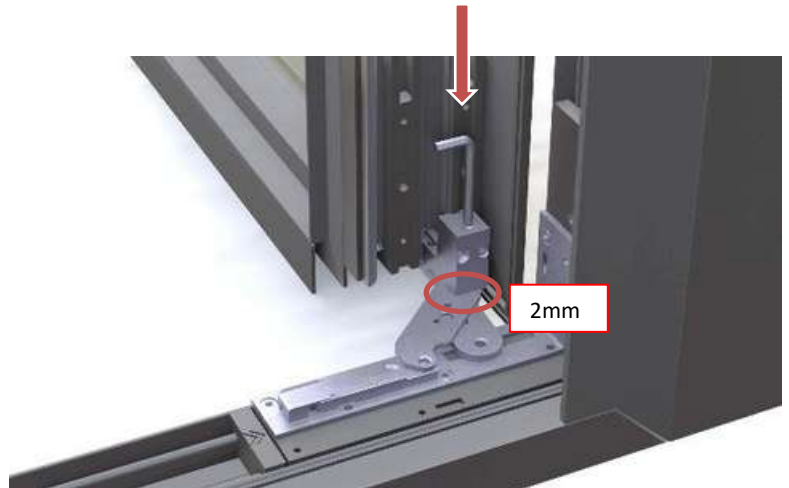



11. Then place the door handles. First place the axle through the lock, then place the door handles on both the inside and outside. Make sure the core pull protection is on the outside. By means of the 3 bolts that run straight through the profile (from the inside to the outside), you pull the door handles towards each other. Tighten it so that the aluminum profile of the main door lies flat.





6.4 Fitting the slide and turn doors

ATTENTION: The slide and turn system contains several slide and turn doors. There is one different slide and turn door per main door; it contains a lock cup profile. This lock cup profile must adjoin the main door! Place this door first to avoid mistakes. Then place the next slide and turn doors on the other side of the main door.

1. Find the different slide and turn door with the lock bowl profile within your order. Place this slide and turn door first, the lock bowl must adjoin the main door.
2. Each slide and turn door contains pre-assembled carriages and hinge parts (3.3). In addition, each slide and turn door contains a separately delivered undercarriage (3.2). Place the undercarriage (3.2) in the correct position in the bottom rail.
 - Check that the adjusting plate in the undercarriage is completely flush with the housing. If this is not the case, loosen the set screws on the top of the cart further.
 - Make sure that the adjusting plate (3.2.1) in the carriage points towards the pass door!
 - As a check: the arrows on the runner must point towards the main door.

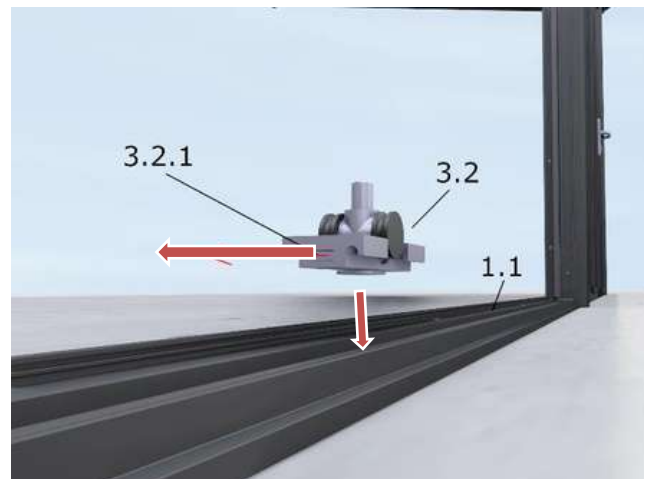

3. Temporarily disassemble the overhead carriage including hinge mechanism (3.3) by means of 4 screws.





4. Open the espagnolette on the side of the door in a horizontal position so that the locking pin (in the top corner of the slide and turn door) retracts.



5. Lift the slide and turn door into "sliding" position with the bottom on the bottom rail.
 - Tilt the door slightly so that there is room at the top to lift the undercarriage over the bottom rail and place it in the rail.



6. While still tilting the door and slightly lifting the bottom corner towards the main door, you can place the bottom hinge on the undercarriage (3.2) (pre-positioned in the bottom rail).



7. Tilt the door back to vertical position. The door should now fit between the bottom and top rails.
 - If this is not the case, one or more carriages are not positioned correctly in the rail, or the height of the bottom hinge has been turned out too far.



8. Make sure that the top of the slide and turn door connects with the top rail of the frame. Then close the espagnolette. This ensures that the locking pin in the top rail locks so that the door cannot tilt out.



9. Then place the overhead carriage in/against the top rail. The arrows should point in the direction of the main door, the rear of the hinge mechanism should fall over the roller cam of the corner insert.

- Make sure the pivot pin in the overhead carriage is in the retracted position. You can check this by pushing back the hinge pin (which runs straight through the overhead carriage and comes out at the top). This puts the spring under tension.
- It is possible that the hinge mechanism of the overhead carriage (3.3) does not fall over the roller cam of the slide and turn door, pulling the roller cam downwards will create more space for placing the overhead carriage (3.3).



10. When the overhead carriage hinge mechanism falls over the roller cam, push it (up) toward the top rail so that the top hinge slots align with the four screw holes in the corner of the slide and turn door.
11. Install the 4 screws, but do not tighten them yet.
12. Hold the overhead carriage under tension against the top rail and check that the hinge mechanism is flush with the slide and turn door. Only then tighten the 4 screws (this is not the final position yet)

Repeat the above operations for each subsequent slide and turn door, place each subsequent door further away from the main door, so that the first door installed remains positioned next to the main door.



7. Adjust and readjust the slide and turn system.

After installation, the slide and turn system must be professionally adjusted. ***An incorrectly adjusted slide turning system causes excessive/premature wear and therefore the risk of loss of warranty.*** We recommend that you check your sliding turning system at least once a year and adjust it if necessary.

It is important that if the door does not function smoothly or is heavily unlocked; the adjustment is checked and readjusted so that the problem is solved. Continuing to use a heavy unlocking system will overload the product.

NOTE: Adjusting the slide and turn system always takes place in 2 main steps. The first step (7.1) must be completed before the second step (7.2) can be started!

Adjusting the doors starts with a fixed (vertical) reference point. It is easiest to start with the slide and turn door on the extreme side of the frame (opposite to the main door).

1. Slide the slide and turn door against the side of the frame.
2. Use the adjusting screw in the bottom hinge (above the under carriage) of the slide and turn door to set the degree of tilt. By turning the screw further in or out, the door will tilt/slant more to the left or right. Turn the screw so that the distance between the side of the frame and the slide and turn door is the same at the top and bottom. Because the frame has been placed level, your slide and turn door is now also level.



3. Then slide the next slide and turn door against the newly adjusted slide and turn door.
4. Adjust this slide and turn door in the same way, by now keeping an eye on the seam between the 2 slide and turn doors. It should run parallel both above and below.
5. Repeat for all slide and turn doors.



6. Then close your main door.
7. Check whether the seam between your main door and slide and turn door (with lock cup) is parallel to each other. If not, you must adjust the hinges of the main door both at the top and bottom to equalize the distance between this seam at the top and bottom.

NOTE: The width of this gap will be adjusted later in this step-by-step plan. The following adjustment is purely for running the doors parallel to each other.

- By turning the horizontal adjusting screw on the hinge you can adjust both the bottom and the top +2 or -2 mm. This allows the main door to tilt up or down so that you can adjust the gap between these 2 doors.

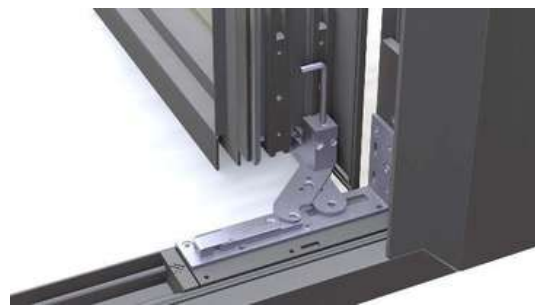

- Check the effect of your adjustment on the gap of the door relative to the slide and turn door (with lock cup) every half turn.

CAUTION: After adjusting in step 7, there may be a knock sound on the door. By adjusting the door too far towards the frame, it is possible that the (vertical) draft brush profiles of the main door and the vertical side of the frame touch each other during the closing of the main door. This gives a tapping sound when closing. If this is the case, you should adjust the hinges so that the main door as a whole extends slightly further from the edge of the frame by adjusting the adjusting screws both above and below +0.5mm to +1mm.

8. If, after adjusting the gap, the main door still runs against the bottom rail at the bottom, or if the hinge does not run freely or if the hinge shows a tap*. Then you still need to adjust it as follows:
 - Turn the height adjustment screw of the corner band (2.2) in the bottom corner of the main door downwards. This raises the main door.
 - Check the effect of your adjustment on the height of the door every turn.
9. Check again whether the seam between your pass door and slide and turn door is parallel to each other. When it runs parallel, you can go to step 10.
10. Check the width of the seam between the barrel and slide and turn door. This should be 3mm to ensure that the lock fits properly in the lock bowl and that the roller cams lock properly when turning the lock.



11. You can adjust the play you have just taken up by slightly increasing the seams between the slide and turn doors by slightly turning the rubber adjustable feet between all slide and turn doors.

- Make sure that the width of the seams between the slide and turn doors are the same over the entire system, by adjusting them evenly. This prevents the doors from sliding into each other because they are too far apart.

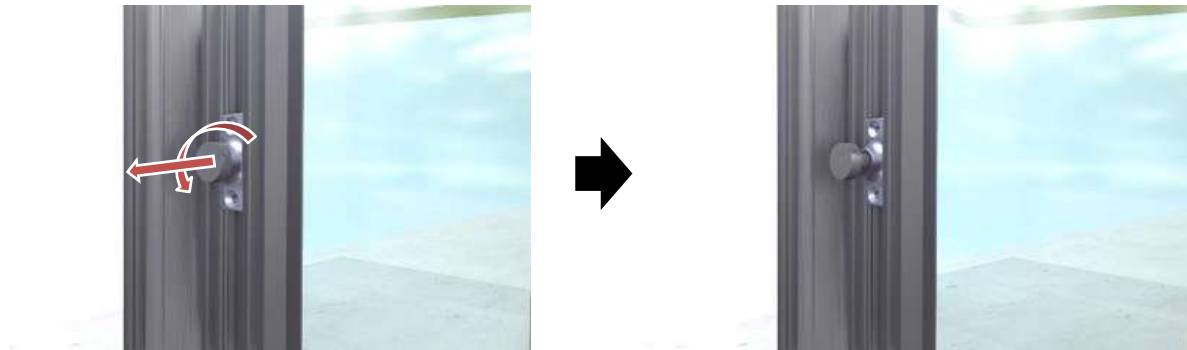



7.2 Adjusting the locking/unlocking mechanism of all slide and turn doors

After installing and adjusting the doors in the closed position (Chapter 7.1), the final step is to adjust the locking/unlocking mechanism of the slide and turn doors. Before starting this, firstly make sure that:

1. All doors connect correctly when closed. Make sure the seams between the doors are parallel and evenly spaced before adjusting the slide and turn door mechanism (Section 7.2).
2. Press the overhead carriage of all slide and turn doors firmly into the top rail. Loosen the 4 screws in the top hinge a few turns. Then push the overhead carriage into the top rail so that it is flush with the top rail. Then retighten the 4 screws. Repeat for all doors.



ATTENTION: A slide and turn door must meet the following conditions (7.2.1 – 7.2.4) to function properly, if this is not the case, the mechanism must be checked and adjusted in ascending order. Therefore, check the following points for correct operation and adjust them if necessary. Follow this step-by-step plan for each slide and turn door. Start at the slide and turn door adjacent to the main door and finish the slide and turn doors in the direction of the main door.



(7.2.1) Locking

When the slide and turn door is slid against the run-on block and locked in the top rail, the slide and turn door should tilt. By tilting, the running wheel under the slide and turn door will float +/- 2mm above the bottom rail.



The hinge pin from the overhead carriage (3.3) should lock itself into the caps which are pre-mounted in the top rail (1.2). You should hear a “click” while locking to make sure the hinge pin is locked to the top rail.

1. Tilting the slide and turn door causes the bottom wheel to float +/- 2mm free from the bottom rail. This release is necessary for correct operation of the unlocking mechanism. The degree of tilt of the slide and turn doors can be adjusted by first setting the basic setting correctly.

- a. The basic adjustment can be obtained by: sliding the guide block in the bottom rail backwards so that the hexagonal bolt is exposed. The hexagonal bolt can be unscrewed a few turns, and then slide the starting block over the hexagonal bolt again.



- b. Check whether the slide and turn door now tilts (and locks) sufficiently and repeat this process if necessary.
- c. You can check that you have achieved the correct basic setting by letting the door lock. With a correct adjustment it is possible to open the espagnolette without resistance after the roller door has been locked.
- d. Check whether this basic setting is sufficient for all successive roller doors. If some do not tilt sufficiently, this can in many cases be solved by turning the basic adjustment a little further.

**If the guide block cannot be slid back far enough to allow the hexagonal bolt to turn freely, shorten the rubbers in the bottom rail slightly. Don't take this too far! Max 2cm from the starting block.*



2. If the hinge pin is not properly locked:
 - a. Check whether the guide block in the top rail is turned out too far to prevent the hinge pin from entering the cap.
 - b. Check that the locking pin in the overhead carriage (3.3) functions correctly and pops up when the release plate in the overhead carriage is pressed. This can be tested manually by pressing the plate in the carriage. Do not forget to manually retract the locking pin before sliding the slide and turn door; to prevent damage to the top rail.
 - c. The spring of the top hinge mechanism can be adjusted more tightly by turning the Allen further in line with the hinge pin.
3. The degree of tilt can be fine-tuned for each individual slide and turn door. Keep in mind that the adjustment of the previous slide and turn door influences the degree of tilt of the rest.
 1. Loosen the rear screw (Fixate) a few turns. This releases the adjusting plate in the lower carriage to allow it to change position.
 2. By turning the front screw (Adjust) further in, the plate on the front of the carriage will protrude further (0 – 2 mm). Because the carriage is moved further back, the door (and each subsequent one) will tilt further.
 3. Tighten the rear screw (Fixate) again so that the adjustment is not changed by vibration.

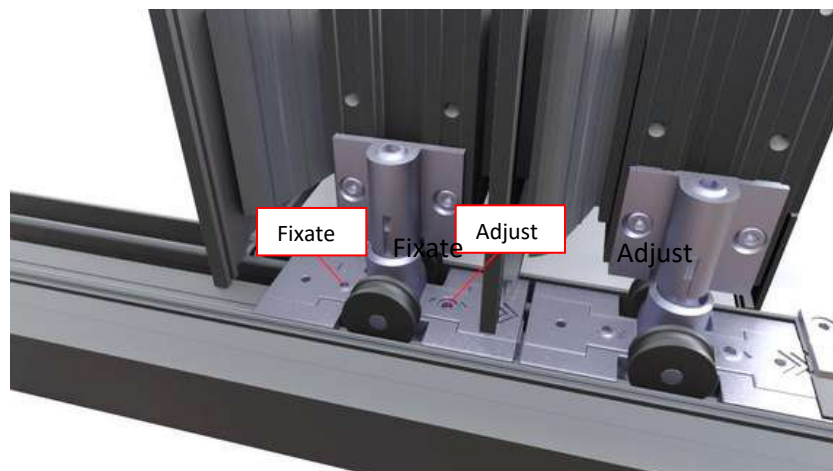



(7.2.2) Opening

When (after locking the slide and turn door in the top rail) the espagnolette is opened, it should open smoothly, without the user experiencing the feeling of hard resistance at one point.



Opening the espagnolette is done in 2 steps;

1. The first half turn when opening the espagnolette (to horizontal position) causes the locking pin in the top rail to be pulled downwards.
2. The second half turn of the espagnolette lifts the idler wheel off the bottom rail.

- a. The espagnolette gives the 2nd half of this opening stroke counter-pressure through the spring mechanism that is incorporated in the system, however, ***it should not be the case that a blockage / hard resistance is felt (however subtle!) while opening the espagnolette!*** If this is the case; this hard resistance/blockage arises because the bottom idler wheel is not hanging 2mm above the bottom rail. The door must then be adjusted in such a way that it tilts further when it hits the run-on block (see point 1 above).



- b. **ATTENTION:** Feeling a hard resistance when opening the espagnolette has a particularly significant effect when unlocking the door. This may cause the door to unlock when the bottom wheel is not fully extended; resulting in the door being unlocked. At this point, the user will continue to apply force to the espagnolette; after all: the espagnolette is not yet completely closed. In this case, the espagnolette will push out the bottom wheel further while the full weight of the door is resting on it. The mechanism of the espagnolette cannot withstand these forces and will cause premature wear or breakage!

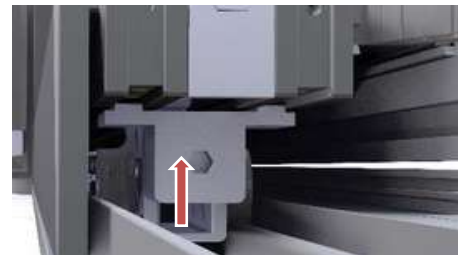

When opening the slide and turn door 90 degrees, do not allow the door to drag/scrattle on the bottom rail.

If this is the case: the door should tilt higher when locking. See point 7.2.1



(7.2.3) Unlocking protection

The Espagnolette/slide and turn door must not be able to be unlocked while the door is in the open position.

At the top of each slide and turn door there is a fall protection mechanism, which is pressed (via the top rail) during the closing of the door.

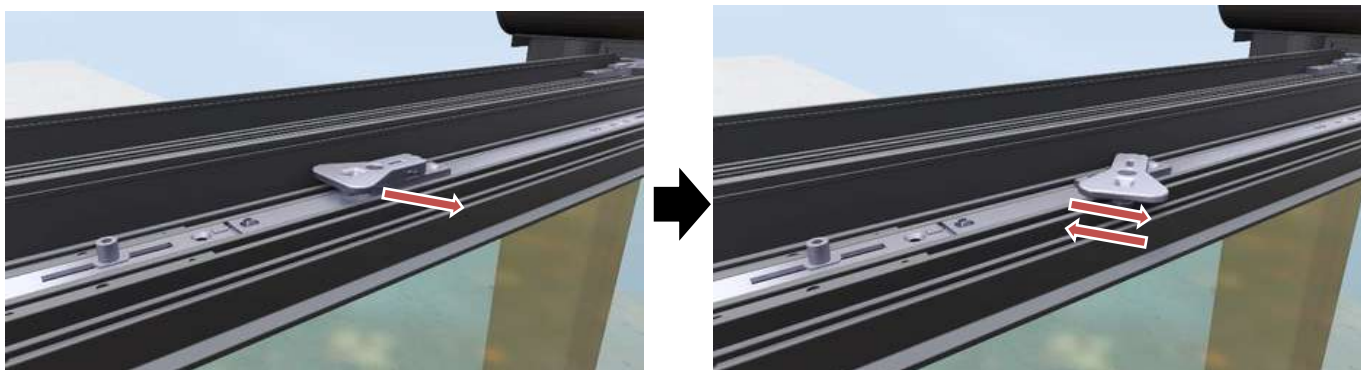

Only when this fall protection is pressed (and the door is therefore closed) can the door be unlocked so that it falls back onto the bottom rail. Check per slide and turn door whether it automatically unfolds when the roller door is opened and whether it is then impossible to unlock the door outside the rail.

CAUTION! Forgetting to activate the fall protection can lead to dangerous situations!
Always check whether the mechanism works for each door.

(7.2.4) Unlocking

The hinge pin (in item 3.3) must be correctly adjusted to function in the following 3 situations:

1. After it has been unlocked by collision of the carriage, it must be fully against the cap in the top rail (1.2) to push.

Check that the locking pin is securely locked in the top rail. To do this, the carriage must run flush with the top rail. When the hinge pin is properly locked into the cap in the top rail, it should have hardly any play when the overhead carriage is wobbled in the direction of the rail.

2. It must then be possible to pull it down again by means of the espagnolette so that it falls behind the plate of the overhead carriage.
3. This should only take place when the slide and turn door hangs above the bottom rail.



This assembly can be adjusted by means of the adjusting screw in the top hinge of the slide and turn doors. Adjusting this screw affects the above 3 things. The intention is to run this in such a way that you find the system in the area where all 3 things below function. In general, the screw is already set correctly and does not need to be changed. If this is not the case then:

1. Fully screw in the adjusting screw
2. Test whether the door is correctly locked and unlocked by sliding it towards the main door.
3. If this is not the case, loosen the adjusting screw a few turns.
4. Test again and repeat this process until the system is working properly.
5. Don't forget to check if the unlocking protection is working.



TIP: (by inserting a pin or small screwdriver in the slots of the hexagon bolt you can apply some force if the screw does not turn smoothly by hand)

CAUTION!: While unlocking it is important to check whether by operating the espagnolette the undercarriage is first fully extended before the door is unlocked from the top rail. If this is not the case, allow the door to tilt further (see Point 7.2.1). **Lifting the slide and turn door by forcing the Espagnolette will damage the system!**



8. Troubleshooting

Problem	Solution
<p>A. I slide the slide and turn door toward the main door to lock (to flip it open) but it won't lock. Check the carriage in the top rail.</p>	<p>Solution 1. Check whether the wheels of the overhead carriage (part 3.3) press properly into the top rail at the location of the hinge pin caps in the top rail. If not, loosen the 4 screws of the top hinge a few turns. While the overhead carriage presses into the top rail under tension, retighten these 4 screws. (Note that the hinge pin must be in the retracted position when the carriage is mounted). Go through Chapter 7 to readjust.</p> <p>Solution 2. Try to manually retract the pivot pin (item 3.3) Check that the pivot pin is locked and unlocked by pushing the plate into the overhead carriage to test the mechanism. Spray it with penetrating oil.</p> <p>Solution 3. Loosen the set screw in the hinge pin (item 3.3) a few turns. Go through Chapter 7 to make sure everything is working properly. Check that the mechanism is working properly by locking and unlocking the door several times.</p> <p>ATTENTION: Also check whether the fall protection still functions properly to prevent dangerous situations. (chapter 7).</p> <p>Solution 4. Check that the guide block in the top rail is fully in the correct position. The run-on block should be set back 1 millimetre in relation to the carriage when it is locked.</p> <p>Solution 5. After a few years, the spring behind the hinge pin (item 3.3) can slacken. By turning the Allen on the underside a few turns, it is tensioned again.</p>
<p>B. I have tried to lock the slide and turn door, when I try to open it with the espagnolette it does not work.</p>	<p>Check whether the hinge pin is locked. If not, see problem A.</p> <p>Solution 1. Check that the door tilts far enough when locking. See chapter 7.2.1. and 7.2.2. Adjust the amount of tilt of the door to ensure that the carriage can be lifted over the rail by means of the espagnolette.</p>
<p>C. I can't unlock the slide and turn door, or unlocking is not smooth.</p>	<p>Solution 1. Check that the door tilts far enough when locking that the carriage is clear of the bottom rail. (Chapter 7.2.1. and 7.2.2.) Adjust the amount of door tilt to ensure that the carriage is a few millimetres clear of the bottom rail when locking.</p> <p>Solution 2. The pivot pin is not retracted far enough to not lock into the overhead carriage. Fully screw in the set screw in the hinge pin (item 3.3) and then</p>



	<p>unscrew it a few turns. Check per turn-out by operating the espagnolette whether the pin now retracts far enough. See Section 7.2.5</p> <p><u>ATTENTION: Also check whether the fall protection still functions properly to prevent dangerous situations. (chapter 7).</u></p>
<p>D. The slide and turn door does not roll properly, it seems to be skewed on the rail. The espagnolette is still open and must be forced to close.</p>	<p>Solution 1. Try to lift the door on the side of the espagnolette a few +- 1cm while pressing the espagnolette. The problem is solved if you can smoothly close the espagnolette. Move your espagnolette up and down 1 more time to make sure the hinge pin is in the retracted position.</p> <p><u>CAUTION: This problem is caused by incorrect adjustment of the door. Make sure the door tilts further when locking, see chapter. Go through chapter 7 to adjust the doors.</u></p> <p>Solution 2. Check that the wheels in the undercarriage (which is pulled up) have not slipped off the axles. Multiple misuse (not tilting sufficiently due to incorrect adjustment) can lead to this damage.</p> <p>Solution 3. There is an Allen key in the undercarriage (accessible when the door is open). Which further tensions the spring in this carriage when it is screwed in. The further tension of this spring ensures that the undercarriage is pressed better into the bottom rail before the door is unlocked.</p>
<p>E. The overhead carriage scratches the top rail and collides with the hinge caps.</p>	<p>Solution 1. The pivot pin is not retracted far enough to not lock into the overhead carriage. Go through chapter 7.2.5.</p> <p><u>ATTENTION: Also check whether the fall protection still functions properly to prevent dangerous situations. (chapter 7).</u></p>
<p>F. When opening the door, it scratches along the top.</p>	<p>Solution 1. The door tilts up too far. Go through chapter 7.2.1 to let the door tilt less. <u>Note: Adjustment affects all doors.</u></p>
<p>G. My slide and turn door is unlocked outside the rail.</p>	<p>Solution 1: Open the Espagnolette completely. Then press it half closed again to retract the pivot pin in the overhead carriage. The hinge mechanism is now back in the active position to lock. Then lift the door and guide the overhead carriage in the direction of the approach block at the location of the main door. By colliding the overhead carriage, it locks again.</p> <p><u>CAUTION: Go through the adjustment in Section 7 again to ensure that the fall arrester functions properly. A poorly functioning fall protection system creates dangerous situations.</u></p>



9. Maintenance

We recommend that you regularly maintain and clean your Sliding Turning System. Check that all screw fasteners are tight. If not, tighten it properly. Check the entire system annually and adjust it if necessary. Make sure that the door panels are perfectly adjusted in height and width to prevent damage when closing the main door.

Check the hinge mechanism of the slide and turn doors annually for operation. You do this by manually pressing the plate in the overhead carriage (part 3.3) to unlock the hinge pin. Then manually pull the hinge pin back and spray the moving parts with penetrating oil. Repeat this several times to allow the oil to enter the mechanism properly. Contaminants can get into the bottom rail. Be sure to keep the rail clean in the interest of its longevity.

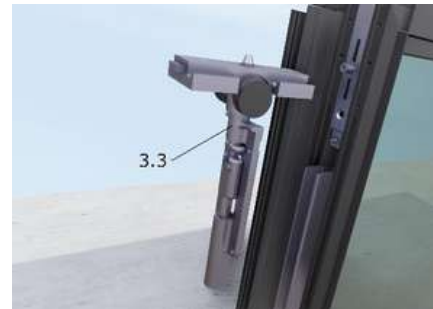

The aluminum profiles and door panels that are contaminated can be cleaned with lukewarm water and a neutral cleaning product.

- Use water, soft material and sponge for cleaning and washing.
- Never use abrasives or aggressive solvents. (No acid or alkalis). Solvents (Dishwashing Liquid and Glassex) are allowed to remove greasy soiling.
- Never use a pressure washer.

10. Disposal

Dispose of the product according to local laws and regulations.

11. Warranty conditions

Warranty according to warranty conditions and general terms and conditions of Viewline. These can be found on the website www.viewlinesystems.com

11. Contact

Your dealer is your first point of contact for questions and comments.